

# A Novel Constant Directivity Horn

By Dario Cinanni

*Editor's Note: This outstanding article on constant directivity horn design is profusely illustrated with 45 images and graphs, which unfortunately will not fit into the available print space for this issue of Voice Coil magazine. The additional figures (marked in blue) as well as the complete article can be viewed here: <http://bit.ly/Cinanni>*

This article was written based on an acoustic simulation study I presented at the Comsol Conference, Grenoble (France) in October 2015 ([www.comsol.com/paper/simulation-of-horn-driver-response-by-direct-combination-of-cd-frequency-respons-28561](http://www.comsol.com/paper/simulation-of-horn-driver-response-by-direct-combination-of-cd-frequency-respons-28561)). In that research, a new simulation method was presented about high-frequency horn driver transducers. The method comprises a horn simulation and a driver plane wave tube measurement.

Combining only this data, using a novel equation that correlates the matrix of the virtual horn and the real compression driver pressure, it is possible to easily predict the absolute sound pressure level (SPL) of the real horn driver frequency response. The results showed a good match between simulations and measurements up to 15 kHz. We found that the main limit is the assumption of a plane wave, which does not hold for higher frequencies. In order to easily understand the content of this article, in particular for audio and acoustic aficionados approaching these topics for the first time, I have left out the mathematic formulas, for which a deeper and distinct analysis would be necessary.

## Hybrid Constant Directivity

The two main reasons why horns are used in sound systems are high efficiency (and consequently high SPL at relatively low distortion) and directivity control. We want to focus on the second point: directivity, as discussed by Bjørn Kolbrek ("Horn Theory: An Introduction Part 1 and Part 2, *audioXpress*, March and April, 2008): an exponential horn can provide the driver with uniform loading, but at high frequencies, it starts to beam. Constant directivity horns, if based on conical shapes only or diffraction methods, are affected by reflecting waves that at high levels could produce distortions. The question is: Is it possible to transform a conventional expansion horn (exponential, hyperbolic sine, hyperbolic cosine, catenoidal, tractrix, spherical, etc.) into a constant directivity horn?

We need to consider a mathematical expansion law of a horn not only as an expansion in terms of an area, but also in terms of a volume. If we keep the defined horn expansion law following the same volume expansion, within certain limits, we can modify boundary profiles to satisfy special needs. The need we want to satisfy is the constant directivity. As we know, the directivity of a horn is controlled down to a frequency that has a wavelength comparable to the horn mouth.

Horn.ell.a is software designed in 2006 and its algorithm doesn't follow Cartesian profiles, as per the usual approach with a horn, but it works on volumes. With the volume process, it is possible to extend expansion profiles for a progressive match between the throat and the different mouth shapes.

The horn's mathematical progression is always guaranteed, so the key is to have a non-deformable volume gradient. In this way, if we want a hyperbolic exponential profile, we will maintain the same load and low-frequency control, but we can also obtain the directivity control on one plane.

The volume expansion is discretized by the X, Y, value numbers. As for the 2D mathematical profile, the 3D volume discretization approximates the selected ideal expansion. Better approximation occurs when reducing the step as it is observable in **Figure 1**. For the current prototypes, on the X-axis for example, an X value is carefully selected to obtain a step of 1.85 mm, thus every 1.85 mm the horn volume adapts its expansion matching the selected mathematical law. This is a coarse step, generating a 61k point's cloud—useful for a demonstration purpose—but for an accurate surface reconstruction of a similar product with this dimension, a finer mesh is suggested—about 1M points.

We can call these new kinds of horns Hybrid Constant Directivity (HCD) and they can guarantee:

- the expansion we already know
- a constant directivity on the plane along its major axis
- an equivalent directivity contour we have with a circular mouth horn (using the same expansion) on the plane along its minor axis

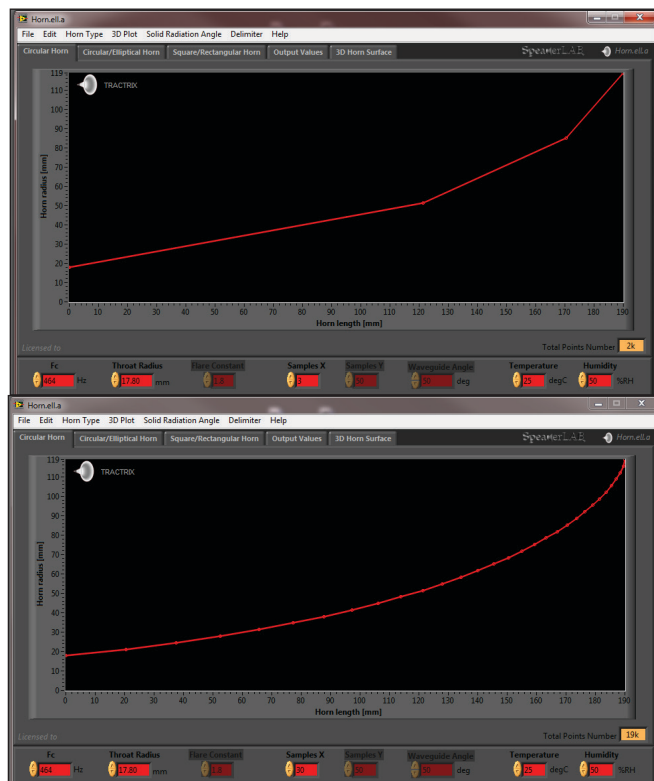

Figure 1: Sample X represents the segments number that approximates the horn volume expansion on the X-axis. X = 3 (left), X = 30 (right).

With this type of horns, the maintenance of constant directivity with frequency in high-frequency exponential horns (and all other expansions) is possible on one plane. A horn with a good loading but a constant directivity (e.g., the HCD horns) is the most natural way to do it. These horns are useful for all applications where directivity control on one plane is requested. On the other plane, the directivity behavior will be similar to a standard circular horn. Various HCD horns are now available on the market, mainly from the Italian professional audio manufacturer as single components and used all over the world in diverse loudspeaker systems.

### Aspect-Ratio

First, we are going to analyze a commercial 1.4" throat elliptical mouth horn (see **Figure 2**), which was designed using Horn.ell.a software. We can use constant directivity

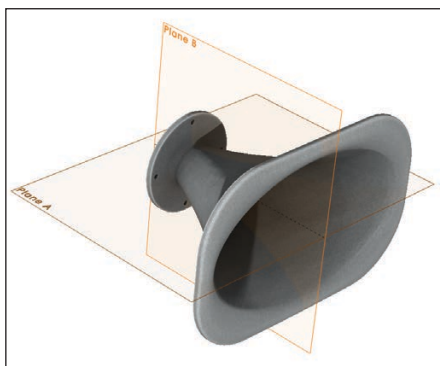

Figure 2: Section planes—Plane A is along the major axis of the horn mouth. Plane B is along the minor axis.

along a vertical line or along a horizontal line; it depends on requirements and by the application. For this reason, to avoid confusion, I prefer to discuss general planes and not vertical or horizontal ones. For convenience, we define two section planes. A is the section along the major axis of the horn mouth (the plane A here is always referred to the constant directivity section plane); while B is the one along the minor axis. This is true when the horn mouth has an aspect-ratio greater than 1. The "mouth aspect-ratio" (MR) is always referred to the horn mouth and it represents the ratio between mouth major and minor axis (see **Figure 3**).

Usually ratios between values of 1 and 1.8 are used. If the aspect-ratio = 1, the horn has a circular or square mouth and we have only one section plane (because PlaneA=PlaneB). Horn.ell.a version 2.0 uses a new routine allowing the user to have aspect-ratios greater than 2,

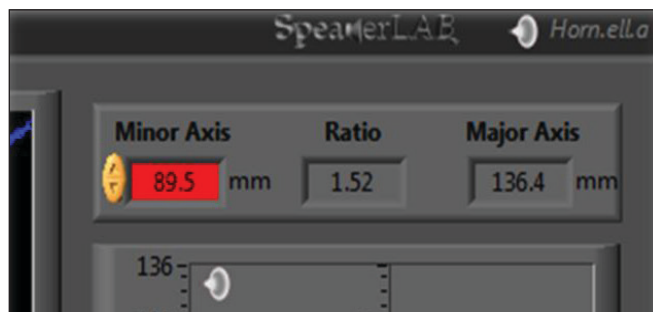

Figure 3: The horn mouth aspect-ratio is the ratio between mouth's major axis and minor axis.



A wide range of components since 1935 :  
 Hard domes, Soft domes,  
 Cones, Dustcaps,  
 Spiders, Surrounds, ...



Loudspeaker components - Made in France

ISO 9001 : 2008 certified

AAC - Applications Acoustiques de Composites  
 ZI Chemin de la Poterie 72340 LA CHARTRE SUR LE LOIR FRANCE - Tel. +33 (0) 2 43 79 03 60 - Fax +33 (0) 2 43 79 20 91

www.aac.fr - lis@aac.fr

maintaining the selected mathematical expansion and reducing wave-front deformations. Modifying the mouth ratio of a horn, Horn.ell.a changes the major and the minor axes, gradually transforming the major axis in a pseudo-conical profile, obtaining an accurate constant directivity on one plane. On the other section plane, the mathematical progression is analogous to the selected one (hyperbolic, tractrix, spherical, etc.).

Next, we will see how it is possible to increase the aspect-ratio, discover how the aspect-ratio value is linked to the constant directivity coverage angle, and determine why the aspect-ratio value is being increased.

### Horn Driver Standard Model

A rigid circular piston (with a planar surface and the same radius of the horn throat) has been modeled as a source to load all the simulated horns. This condition produces an acoustic pressure, in order to predict the horns' directivity. The standard model generates directivity as seen in **Figure 4** and **Figure 5**.

Analyzing the results, starting from a certain frequency the simulated high-frequency band, as we can see from the Figure 4 and Figure 5 contours and is different compared to the measurements graphs shown in **Figure 6** and **Figure 7**.

The scope is trying to study in detail the horn driver high-frequency directivity behavior, in order to improve the simulation results and also to calibrate the model. This step is necessary if we want to predict the horns' directivity plots with a good accuracy. The measurements were done using a compression driver mounted to the real horn as shown in Figure 2; together they produce a frequency response (see **Figure 8**).

If we put the compression driver phase-plug design

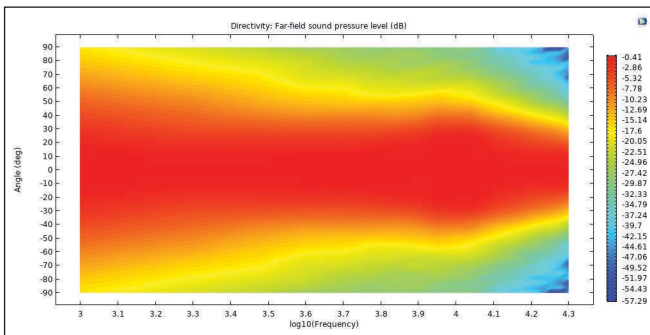

Figure 4: Simulated Plane A directivity plot

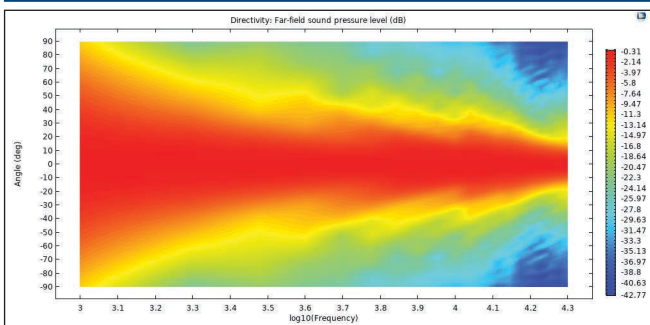

Figure 5: Simulated Plane B directivity plot

into the simulated model, we can see that the simulations of **Figure 9** and **Figure 10** and the measurements of **Figure 11** and **Figure 12** are similar, with an improved match at higher frequencies.

This is due to phase-plug acoustic expansion on its channels exit. Consequently, starting at a certain frequency, which depends on the horn throat diameter, the higher frequency directivity depends more on geometry, shape, channel number, and mathematical progression of the phase-plug.

Simulation accuracy is obtained when we model the full horn driver, with the entire compression driver, because the systems are strongly coupled, hence they can't be decoupled. However, with some smart ideas we can reduce the error to an acceptable level. My target is to have a general and valid horn model independent of the compression driver, but high frequencies will always be a challenge.

Considering the chromatic match between simulations and measurements of the directivity color plots, in the next graphs (**Figure 13** and **Figure 14**), we can appreciate a numerical match of the beam-width. Beam-width is defined here as the coverage angle in which an SPL loss of 6 dB occurs relative to the zero degrees reference angle (the on-axis direction).

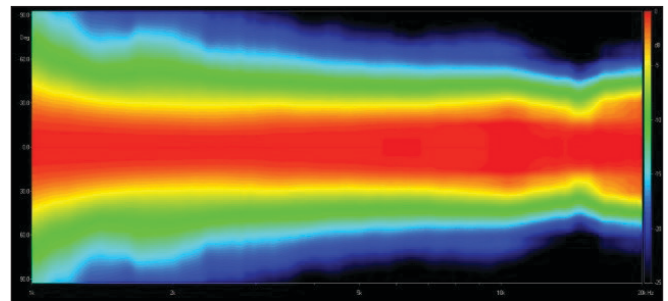

Figure 6: Measured Plane A directivity plot (smooth 1/2 octave)

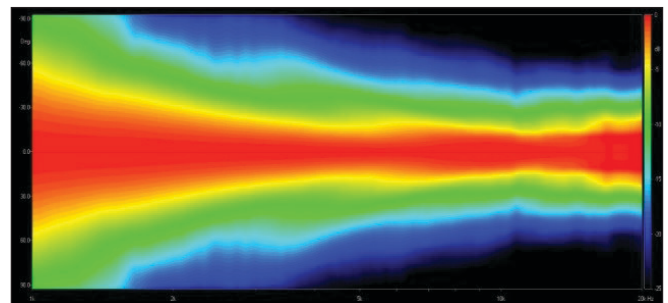

Figure 7: Measured Plane B directivity plot (smooth 1/2 octave)

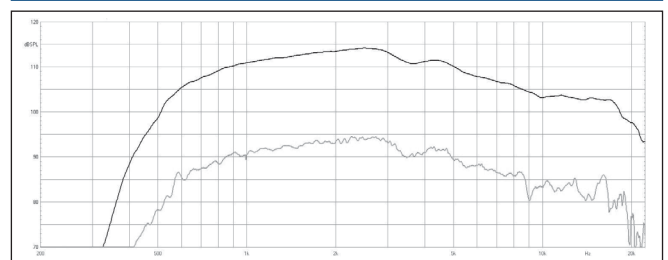

Figure 8: The horn driver is shown at 1 W frequency response. The microphone is set at 1 m distance from the mouth axis. The measurement was taken in anechoic room in a free-field condition. The upper curve is a smooth 1/3 octave, the lower curve -20 dB unsmoothed frequency response.



# PUNKTKILDE™

Designed by Scan-Speak Transducers



## “Dual-Suspensions” Series of Transducers

From 2” up to 5.25”, using our patented Dual-Suspensions design; breaking the rules on traditional suspension transducers, to deliver high excursions and extremely low distortion. With this innovation on transducers design, now you can design small, compact systems without compromising performance.



## Magnesium-Lithium Alloy Cone Series of Transducers

PUNKTKILDE has developed a series of transducers utilizing Magnesium-Lithium (Mg-Li) Alloy cone material, from 1” Dome Tweeters up to 8” Woofers. This unique alloy material has good damping properties, low cone density, high stiffness, and low moving mass, delivering good pistonic behavior and fast transient response.



As we can see in Figure 13, on Plane A the beam-width is well controlled, in this case we see a coverage angle of 62.3° in the frequency range 1.35÷20 kHz. On Plane B (Figure 14) from 4 kHz upward there is a regular beam-width, but it exceeds 6 dB, moreover it is not fixed but it depends on the selected expansion. So for the Plane B, we can calculate an average value but in my opinion it is not formally correct to give a unique value because the reader, or a buyer of a similar product, could be misled when comparing HCD to CD horns. This rule is also valid for all cases of horns with a non-constant directivity beam-width (e.g., all pure profiles such as exponential, tractrix, spherical, etc. with a circular mouth). It doesn't make sense to declare a coverage angle with a single value in a similar situation because we can use them, but these horns in pure shapes were not designed for this purpose. For HCD horns, we can use, for example, the wording "coverage

angle x selected expansion," so the Figure 2 horn could be a commercial 60° x Hyperbolic. For that reason, I introduced the name "Hybrid" constant directivity horn.

We also need to consider, for a better organization of this work that between 1 kHz and 2 kHz there are no other simulated points, as we see in Figure 13 a straight line between these two frequencies. From the beam-width analysis, we can see that it is possible to improve the model simply by adding a phase-plug. Up to 15 kHz the simplified model works well for our purposes, because you must always take into account that a different phase-plug (so a different compression driver!) will influence the upper frequency range. Therefore, we can work with 3D horn simulations only—considering the model's reliability—paying attention to all next directivity and beam-width plots and not considering the high frequency (>15 kHz) beam, because as we have previously seen in real conditions, the directivity depends on the horn-driver combination.

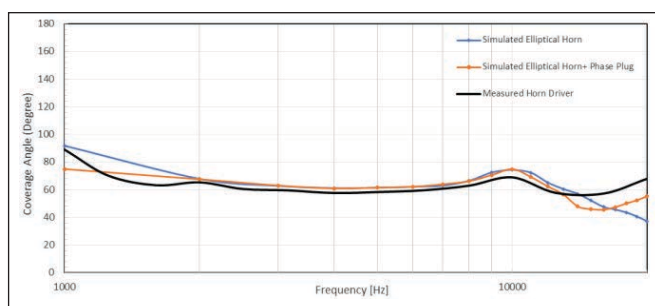

Figure 13: Beam-width measurement and simulations on Plane A

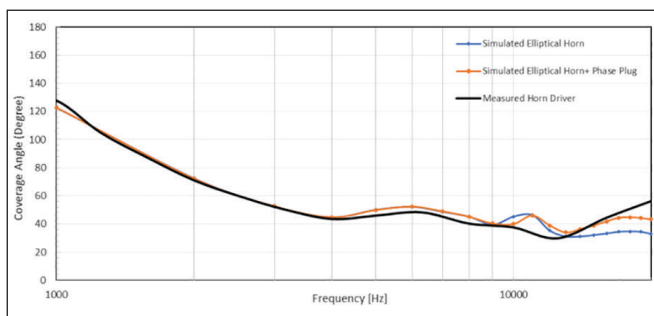

Figure 14: Beam-width measurement and simulations on Plane B

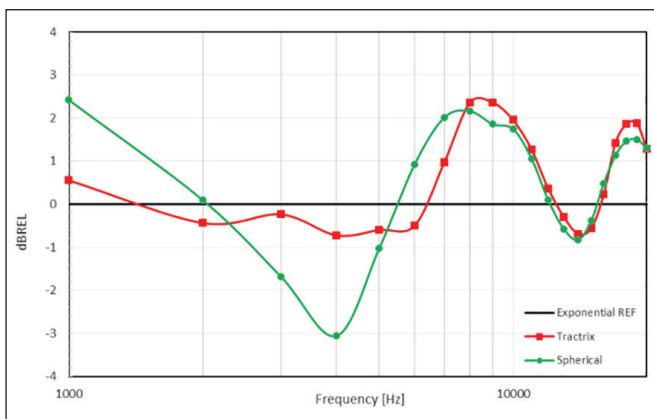

Figure 15: This is the normalized exponential horn frequency response (REF) and the relative difference of a Tractrix and a Spherical (Kugelwellen) horn referenced to the exponential one. The simulation is at 1 m distance on axis.



Figure 18: Elliptical mouth horn's arrangement. MR = 1.7



Figure 19: Elliptical mouth horns arrangement. MR = 2.4

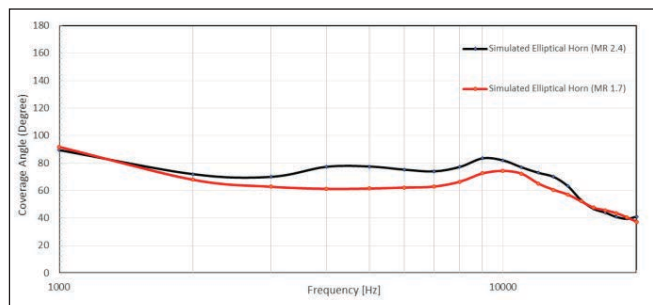

Figure 28: Elliptical mouth horn's beam-width comparison. Horn with MR = 2.4, compared to the horn with a MR = 1.7. Plane A.

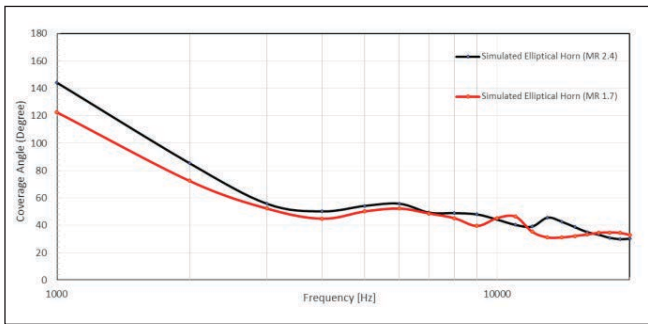

Figure 29: Elliptical mouth horn's beam-width comparison. Horn with MR = 2.4 compared to the horn with a MR = 1.7. Plane B.

## Horn Expansion Efficiency

One of the most efficient horn expansions is the exponential profile. This horn is extraordinarily efficient as an acoustic transformer device due to its impedance match between the source of sound at the throat of the horn and the atmosphere into which the horn mouth radiates. But what is the SPL difference between a pure exponential expansion and the other types?

The horns shown in **Figure 15** were designed starting from the same values. This interesting graph shows that near the cut-off frequency the tractrix and the spherical have more pressure. This is mainly due to the natural flared mouth of these expansions, compared to the pure exponential expansion whose calculus has an unflared mouth. Then there is a range where exponential has more

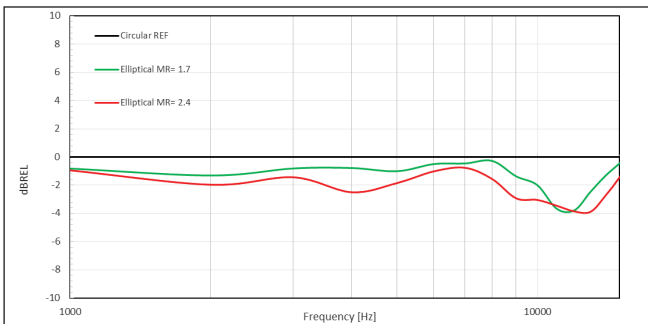

Figure 30: The normalized exponential Circular (MR = 1 REF) horn frequency response and the relative SPL difference of the same horn expansion is shown with modified mouth ratios. Elliptical MR = 1.7, Elliptical MR = 2.4 referenced to the Circular one. Simulation is shown at 1 m distance on axis.

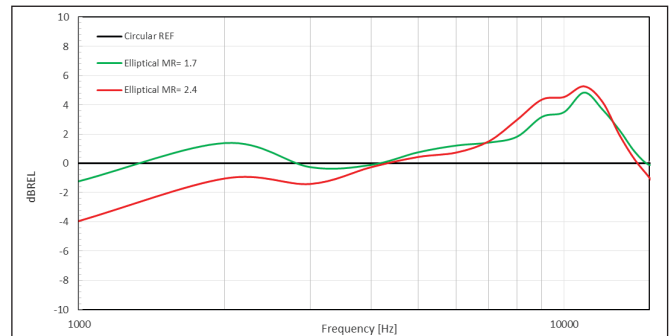

Figure 31: This is the same configuration as shown in Figure 30 but the microphone is positioned at 45° off-axis on the Plane A.

LECTURE  
INVITATION!

## Sound Quality of Audio Systems Modelling, Measurement and Control

### 3-DAY LECTURE IN DRESDEN

**March 9<sup>th</sup> - 11<sup>th</sup>, 2020**

presented by Prof. Dr. Wolfgang Klippel  
at the Technical University of Dresden, Germany.

Join students and engineers from around the globe  
for the three-day lecture 2020.



energy followed by a range where tractrix and spherical have an averaged increased SPL.

Starting from a pure exponential circular mouth profile, which produces directivity we already know for this standard horn type (see **Figure 16** and **Figure 17**), we want to obtain two different horns simply acting on the minor axis value to increase mouth ratio, defining two horns with two different ratios,  $MR = 1.7$ ,  $MR = 2.4$  (see **Figure 18** and **Figure 19**).

When  $MR > 1$ , it is not possible to build a horn only from the two axes shown in **Figure 18** and **Figure 19**; it is necessary to use a 3D file with all 3D points in the space. In **Figures 20–27**, the directivity plots of the two designed horns are reported. Horns are in a pure exponential expansion with two different mouth ratios. The directivity of the same horns is also shown with a flare added to the original design, from which it is possible to understand the importance of a flared expansion at the horn mouth. We can read more about this point in the next section of this article.

In **Figure 28** and **Figure 29**, we can compare beamwidth of the two elliptical horns. The two mouth ratios have a different constant coverage angle on the Plane A, useful for a different application, respectively  $65^\circ$  ( $MR = 1.7$ ) and  $75^\circ$  ( $MR = 2.4$ ). Furthermore, when increasing MR, we are also increasing the constant directivity.

Analyzing the sound pressure between the circular horn and the elliptical one, we can see in **Figure 30** the relative SPL difference. Obviously, the circular horn has more energy because its beam width is focused on axis, while elliptical one

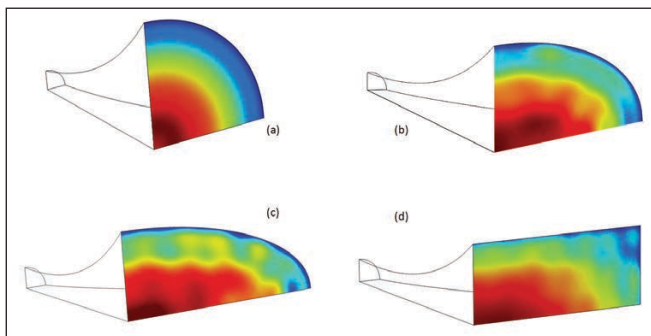

Figure 32: Horn mouth sound pressure distribution at 10 kHz. Circular (a), Elliptical  $MR = 1.7$  (b), Elliptical  $MR = 2.4$  (c), Rectangular  $MR = 2.4$  (d)

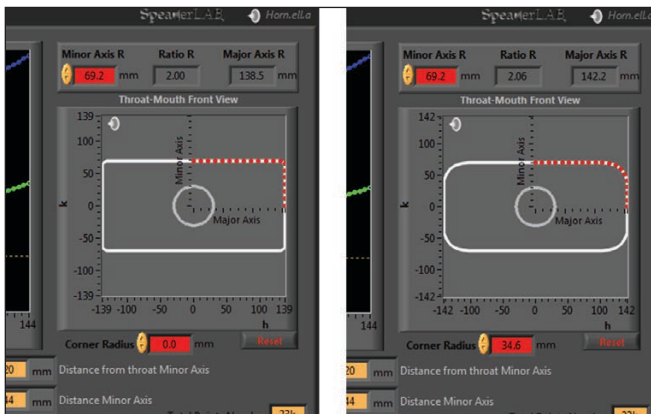

Figure 33: This is the corner radius adjustment for square and rectangular mouths. Radius = 0 and radius > 0.

have a spread energy around the space because they cover a bigger angle on the Plane A. Due to its structure, the elliptical horns cover a larger area and for this reason, we have an SPL loss. Instead, it's interesting to see that the decibel loss for the two elliptical horns is not too much compared to the circular one. Moreover, a decibel loss is controlled for a great portion of the frequency band.

Also, we can see that when increasing the MR value we increase a decibel loss on-axis, because of an SPL off-axis on Plane A intensification. Indeed, when simply moving the microphone  $45^\circ$  off-axis, we can see in **Figure 31** an interesting difference among the horns. For example, the elliptical  $MR = 1.7$  has more SPL on the greater part of the frequency range compared to circular.

Today, with available simulation tools, is very simple to plot a horn mouth sound pressure distribution matrix. Next, **Figure 32** shows a one-quarter solid model of the before-mentioned horns, with the relative surface mouth SPL distribution plots for the center band frequency: 10 kHz.

As shown in **Figure 32d** the rectangular horn, compared to the elliptical ones, suffers of the "corner effect," which is because of reflections. For every single frequency we will have a different behavior near the corner and it can influence the wave-front distortion and the horn's general performance. About this point, elliptical mouth horns are better than rectangular ones. **Figure 34** and **Figure 35** are useful for a comparison with the other presented directivities.

In Horn.ell.a, a design section related to square and rectangular mouth horns has been added (which will be available soon) and in this section it's possible to add a corner radius (see **Figure 33**). To reduce wave-front

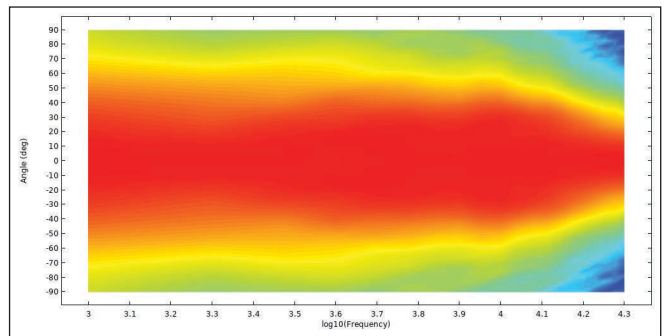

Figure 34: Rectangular flared mouth ( $MR = 2.4$ ) exponential horn directivity Plane A

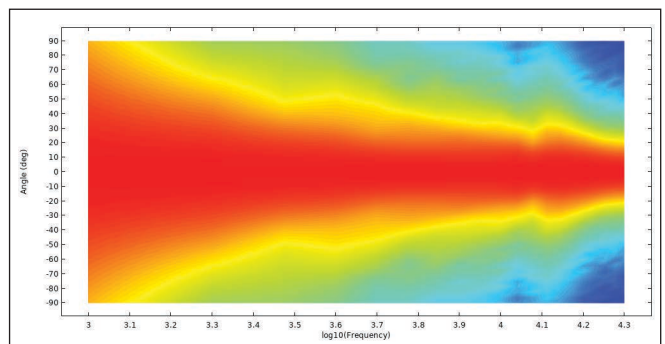

Figure 35: Rectangular flared mouth ( $MR = 2.4$ ) exponential horn directivity Plane B

deformations, maintaining a constant directivity on Plane A, the software will adapt the progressive shape of the corner on each volume step, from throat to mouth.

### Horn Wave-Front Shape

Analogous to the coverage angle, the coverage area is defined as the area limited by the isobar having a level of 6 dB below the maximum value found on the sphere. The coverage area gives useful information about the horn wave-front shape. The HCD horns generate a wave-front shape with a flat zone that has a contour similar to the horn mouth that generates it. In **Figures 36–38**, some examples of the wave-front shape at 10 kHz of the analyzed horn models are shown.

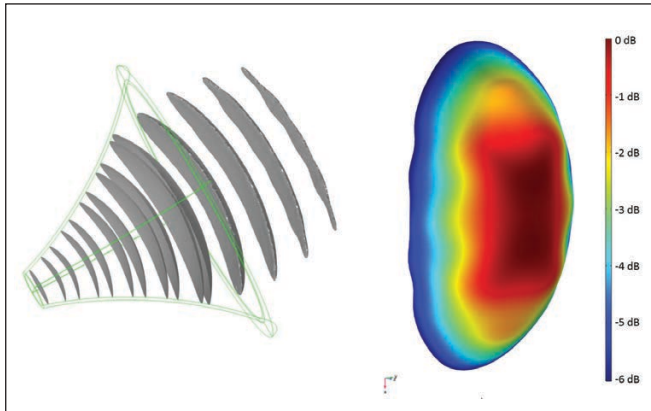

Figure 36: Wave-front shape (left) and particular of the coverage area (right) of the elliptical flared mouth (MR = 1.7) exponential horn

### Mouth Diffraction Effects

There are two studies published by D. B. Keele, Jr. in the early 1970s that disclose the importance of mouth flares. The first is “Optimum Horn Mouth Size” presented at the 46<sup>th</sup> Audio Engineering Society (AES) Convention, while the second one was in Appendix 2 of the preprint 1038 presented at the 51<sup>st</sup> AES Convention. Some types of horns have a flared mouth, tractrix, and spherical horn expansions, while the hypex family horns (exponential is included in this family, flare constant  $T = 1$ ) has an unflared mouth.

Now we’ll see the differences in the directivity polar patterns between a standard exponential horn compared to the same shape but with a flared mouth. From the graph

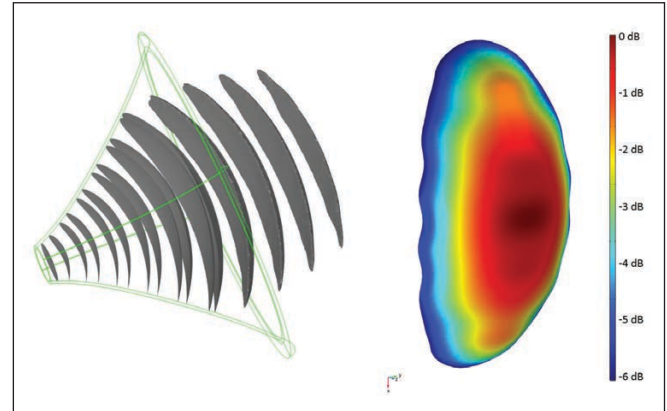

Figure 37: Wave-front shape (left) and particular of the coverage area (right) of the elliptical flared mouth (MR = 2.4) exponential horn

**SPECIALIZING IN** high-temperature edge-wound and multiple layer flat-wound coils for the pro audio, home theater, and automotive aftermarket

- Highest quality domestic or imported coils.
- Custom coils available in:
  - Multi-layer wire configurations
  - Multiple lead configurations
  - Round and Flat Wire
  - Custom lead-out attachments
  - Free standing coils
  - Multiple wire types
  - Bifilar or Edgewound
  - Custom bobbin wound coils
- High temperature adhesive coated Copper and Aluminum wire in round and flat sizes. CCAW wire available in round sizes.
- Adhesive coated custom cut forms and Collars.
- Custom slit rolls of Form and Collar material available coated or uncoated.

**Precision Econowind LLC**  
 8940 North Fork Drive, North Fort Myers, Florida 33903  
 Phone (239) 997-3860 Fax (239) 997-3243  
 For samples, information, or a quotation, please contact Jon Van Rhee at jon@precisioneconowind.com

**Po Yun**  
 ISO / TS 16949 Certified

- ISO 9001-2015
- ISO 14001
- TS 16949

**Visit us on the web at [www.precisioneconowind.com](http://www.precisioneconowind.com)**

**LET US TAKE THE GUESSWORK OUT OF AUDIO**

SPEAKERS | DYNAMIC RECEIVERS | MICROPHONES | AUDIO-SUB ASSEMBLY  
 WATERPROOF | WATER RESISTANT SPEAKERS & MICROPHONES

- CUSTOM DESIGN CAPABILITIES
- SOPHISTICATED TESTING
- EFFICIENT MANUFACTURING
- EXPERT TECHNICAL ASSISTANCE

TELECOM | IOT | FIRE AND SAFETY | MEDICAL | HIGH TEMPERATURE

[WWW.STETRON.COM](http://www.stetron.com)

LET US KNOW HOW WE CAN HELP YOU LAUNCH YOUR NEXT AUDIO PROJECT.  
 CONTACT US TODAY. 1-800-925-3002

**STETRON**



shown in **Figure 40**, we can see the frequency response deviation of the circular mouth exponential horn with a flared end loop, from Figure 39, along its mouth profile.

**Figure 41** shows the same comparison but related to the elliptical mouth exponential horn (MR = 2.4), using a similar flared end as shown in Figure 39. The flare shape is not optimized for a specific application and it's shown for the higher mouth ratio (2.4) horn, because it represents the worst case.

Analyzing the elliptical mouth exponential horn (MR = 1.7) polar patterns shown in **Figure 42**, we can see that on the constant directivity Plane A, the flared mouth has a very small influence on the off-axis horn performance, because the wave-front is guided by the pseudo-conical shape. In Plane B, shown in **Figure 43**, the flared mouth has a significant influence due to acoustic

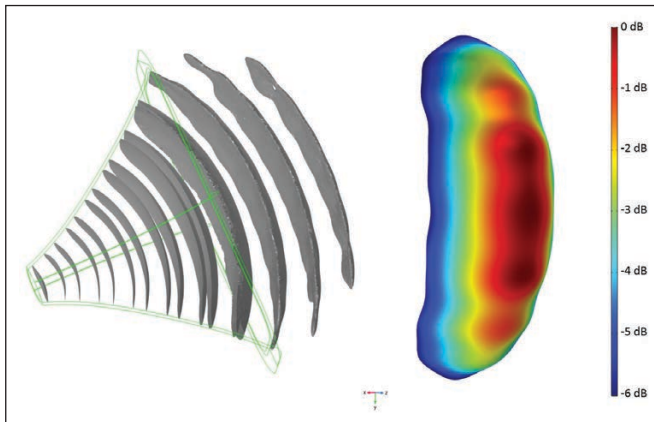

Figure 38: Wave-front shape (left) and particular of the coverage area (right) of the rectangular flared mouth (MR = 2.4) exponential horn

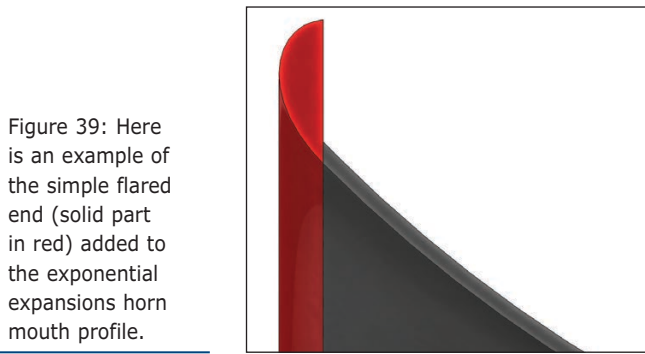

Figure 39: Here is an example of the simple flared end (solid part in red) added to the exponential expansions horn mouth profile.

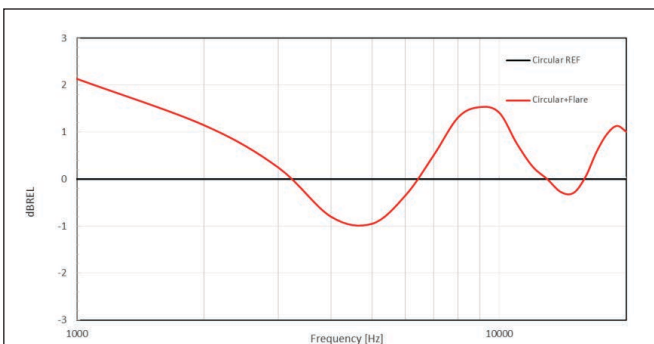

Figure 40: Normalized on-axis frequency response curve of the circular mouth exponential horn with the flared mouth (red), referenced to the same horn with the unflared mouth (black)

pressure diffractions, as the wave-front expands with the exponential progression.

As I mentioned earlier, there is not a unique profile to build a flared mouth, but we need to differentiate it along the loop. Resuming, with the horn constant directivity profile, Plane A, we can reduce the flare dimension as it has a minor impact. On the contrary in Plane B it has a great importance and it must be accounted for to obtain a good directivity, frequency, and impulse response at the same time. The frequencies where we can find problems on directivity polar patterns depend on the horn's geometry, dimension, and expansion and in this case are in the range 5÷8 kHz.

Please note that the according to a polar pattern analysis for a horn application in full space ( $4\pi$  steradian solid angle), indeed the problems could be outside the

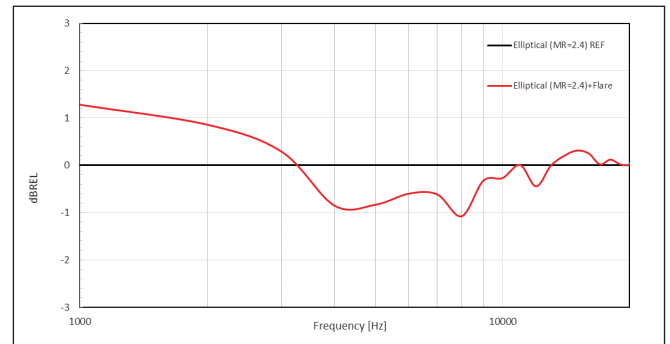

Figure 41: Normalized on-axis frequency response curve of the elliptical mouth exponential horn (MR = 2.4) with the flared mouth (red), referenced to the same horn with the unflared mouth (black)

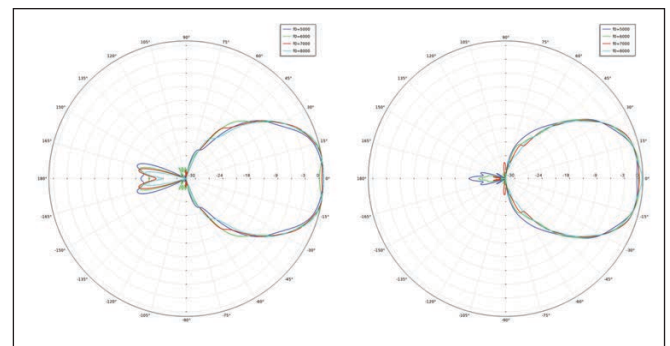

Figure 42: Elliptical mouth exponential horn (MR = 1.7) polar patterns on Plane A. Unflared (left) and flared mouth (right)

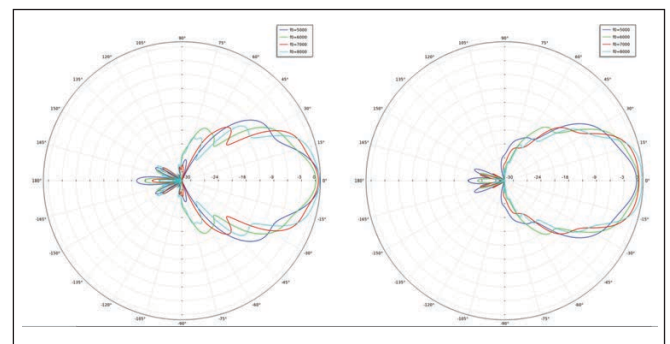

Figure 43: Elliptical mouth exponential horn (MR = 1.7) polar patterns on Plane B. Unflared (left) and flared mouth (right)

horn coverage angle, but when we apply the horn in half space ( $2\pi$  steradian), meaning that horn is applied on a panel, the flared mouth could have a different result. Underlining that the flared mouth shown in Figure 39 is not designed for a  $4\pi$  steradian application, but it is specific for  $2\pi$  steradian.

In general for  $2\pi$  steradian it is also necessary to study the interactions between the horn mouth and other obstacles influencing directivity, frequency, or impulse response (e.g., if the horn or the other loudspeakers are flush mounted).

## Conclusion

In this article I have presented a new type of horn, investigating some practical aspects of constant directivity

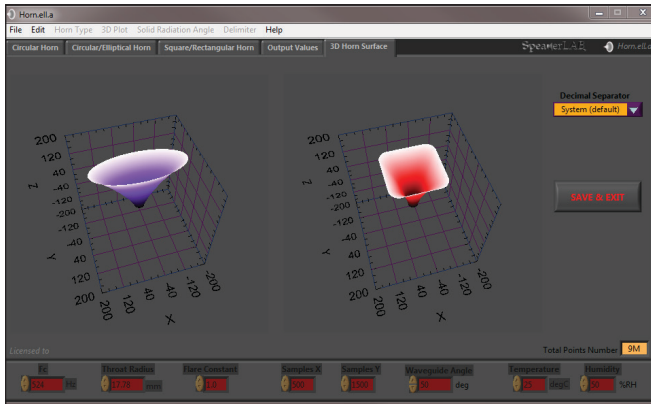

Figure 44: Horn.ell.a 3D horn surface reconstruction example

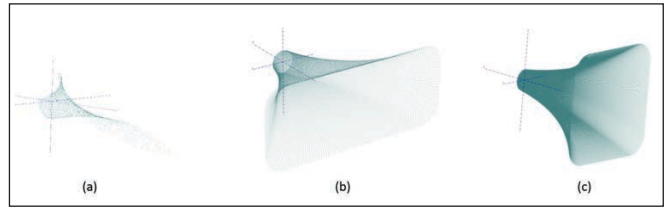

Figure 45: CAD model when open shows a .asc file. Quarter model (a), full angle model (b), model with a finer resolution (c).

horns design through real and FEA simulated prototypes. I called the new horn family Hybrid Constant Directivity (HCD) horns. All horns described here have been designed with SpeakerLAB Horn.ell.a 2.0, without any CAD modification on acoustic boundaries. The only particulars designed externally by Horn.ell.a are the mouth flare adapters for exponential horns. For mouth ratios greater than 1, Horn.ell.a calculates HCD horns regardless of the selected expansion.

The latest Horn.ell.a version, shown in **Figure 44**, manages circular/elliptical and square/rectangular horns at the same time, saving them directly in a 3D file extension .asc. This is a standard code for information exchange ASCII encoding file, easy manageable by most CAD systems available today. When opening the .asc file with your CAD, you can see the model as shown in the **Figure 45**. More information about SpeakerLAB Horn.ell.a is available at [www.speakerlab.it](http://www.speakerlab.it).

Last, I would like to thank Alfred Svobodnik and Giovanni Di Gesù for technical examination and proofreading. **VC**

**Exhibitor Registration now open! Call for Content open!**

**NEW Content. NEW focus.**

**NEW collaboration with InfoComm.**

**Exhibitor Prospectus** available **NOW!** Reserve your exhibit space now to take advantage of our targeted, professional attendees and save money. Get your Prospectus at:

<https://almaint.org/elementor-5181/>

**Call for Content** has been issued! Share your expertise and position you and your company's expertise in the industry. Deadlines soon! Get your call for Content at:

<https://almaint.org/alti-expo-2020-content/>

*The Evolution Revolution continues....*



High Performance Ribbon Drivers and Planar Headphones



**BESTON Technology Corporation**

Address: 4F, No.99, Lide St., Zhonghe Dist., Taipei 23556, Taiwan

TEL: (886)-2-23892956 FAX: (886)-2-23892952

E-Mail: [service@ribbonspeaker.com.tw](mailto:service@ribbonspeaker.com.tw) ; [beston2000@gmail.com](mailto:beston2000@gmail.com)

<http://www.ribbonspeaker.com.tw>